

## SW6000 SEISMIC VIBRATION SWITCH

### Hazardous Area Installation Manual

Before proceeding to wire and install the SW6000 switch, read and thoroughly understand these instructions. They are intended for experienced personnel who require only basic installation guidance, and assume that the SW6000 has already been selected and applied properly for the machinery at hand. Please contact Metrix or its local representative for additional assistance. See also the Supplementary Information Section for additional technical resources.



This electronic equipment was manufactured according to high quality standards to ensure safe and reliable operation when used as intended. Due to its nature, this equipment may contain small quantities of substances known to be hazardous to the environment or to human health if released into the environment. For this reason, Waste Electrical and Electronic Equipment (WEEE) should never be disposed of in the public waste stream. The “Crossed-Out Waste Bin” label affixed to this product is a reminder to dispose of this product in accordance with local WEEE regulations.

### OVERVIEW

The SW6000 Seismic Vibration Switch offers basic protection against gross changes in structural seismic acceleration.

This electronic switch is a versatile excessive vibration protection instrument. In its standard configuration, the SW6000 is an economical single set point vibration switch with standard features and packaged in industrial grade housing with available hazardous area certifications. Fully configured, the SW6000 provides for local machine control with optional LCD readout and real time remote operator interface via a 4-20 mA output.



### SUPPLEMENTARY INFORMATION

Refer to Metrix Datasheet #1009462 and Metrix Installation Manual #M9005 available at [www.metrixvibration.com](http://www.metrixvibration.com).

# MOUNTING

The sensitive axis of the switch can be mounted on any radial axis, although the horizontal axis is preferred so the unit sees maximum vibration. The horizontal axis also reduces the temperature exposure versus a vertical axis. If a bracket is required, it should be rigidly constructed to prevent spurious mechanical resonances in the SW6000 frequency range.

## Stud Mount Unit

The Stud Mount Unit requires a tapped hole, see Metrix Datasheet (doc #1009462) Option "F" or use a Metrix model 7084 flange mount adapter. If an NPT mounting stud is selected, the stud will tighten before the switch casing touches the machine case. The SW6000 should be hand tightened and then wrench tightened to bring the conduit connections to the appropriate location. Studs with straight threads are provided with a locking nut.

The optional display can be rotated in 90 degree increments to bring it to a readable position. Refer to the Wiring Section for further information.

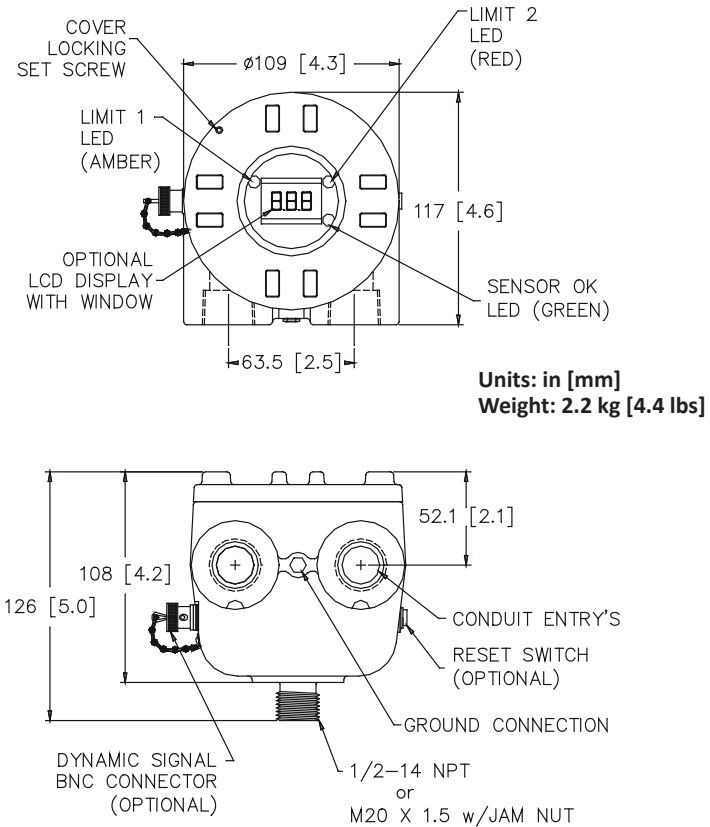

Figure 1: Housing

Aprox. Weight 27.2 g (0.61 lbs)  
Dimensions in mm [in]

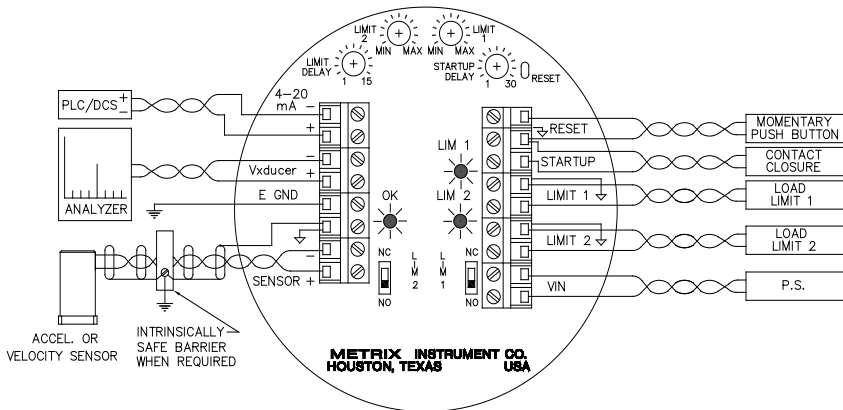

Figure 2: Wiring Diagram (LCD option not shown)

**NOTES:**

1. Diagrams show all available options, see SW6000 datasheet (doc# 1009462) to verify options on your particular unit.
2. On Single Limit Models, use Load Limit Two (2).

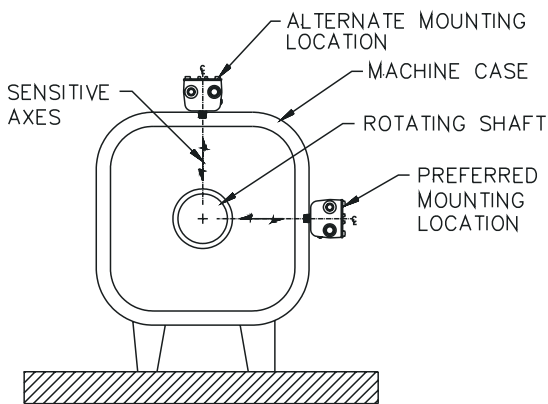

Figure 3: Mounting Locations

**AGENCY APPROVED PRODUCT**  
 DO NOT DEVIATE FROM DOCUMENTED  
 CONSTRUCTION OR LISTED PARTS

## CONDUIT

When attaching conduit, observe the following:

- Avoid long runs of unsupported conduit. Such runs can transfer unwanted impacts or vibration of the conduit, rather than of the machine.
- Orient conduit such that accumulated moisture or condensation does not drain into the switch and consider the use of J-traps or other drain mechanisms.
- The unit with NPT stud mount (ordering option F=0) have ½" NPT stud mount and ¾" NPT conduit entry. Metrix Accessory Part Number 7084-001 can be used with this unit if mounting requires three equally spaced 6.6 (2.6) diameter mount holes on a 38 (1.5) diameter circle. The unit with M20 x 1.5 unit (ordering option F=1) have M20 x 1.5 conduit entry.
- Use proper conduit seals meeting the environmental requirement of the installation to prevent ingress of moisture and dust.

**NOTE:** The disposable plastic plugs that ship in each conduit hole provide only physical thread protection during shipping and handling. They are not designed for use as permanent hole plugs and do not provide adequate environmental protection for the switch when installed in the field.

## WIRING

### Terminal Wiring

If you have selected the optional display, the display circuit board must be removed (two screws) to expose the terminal strips. The display board cable should not be disconnected. Simply place the display board out of the way to allow wiring to the terminal strips. The display may be reinstalled in any of the four possible orientations. Connection to the unit is through one or two conduit entries (See Metrix Drawing 9030). The cable gland or conduit entries shall be in accordance with 13.1 of EN60079-1 and IEC60079-1. The user must provide appropriate seal and sealing materials for the rates installation. Unused conduit entries must be plugged with a plug that conforms to Clause 13.2 of EN60079-1 and IEC60079-1. The internal ground connector allows for the connection of a 14 AWG wire. This has a cross section of 2 mm<sup>2</sup>. The external ground terminal can accommodate a 10 AWG wire that has an cross section area of 5 mm<sup>2</sup>. It is comprised of an M5 bolt with two flat washers and one lock washer.

**NOTE:** On ATEX/IECEx approved units, a locking set screw must be loosened prior to lid removal.

Refer to Figure 2 for wiring information. For incoming power and switch output(s) use approved wire of 14 AWG (1.5 mm<sup>2</sup>) or smaller.

**NOTE:** On ATEX/IECEX installations, a means for disconnecting power to the switch must be provided. Also, the symbol  signifies a protective earth terminal. For reset and startup delay functions, use a twisted pair to reduce electrical noise pickup.

For the current and dynamic signal outputs, a shielded twisted pair is recommended. By convention, the shield should be tied to common only at the receiver end. A cable consisting of separate shielded twisted pairs can also be used. For the dynamic signal output, the capacitance of the cable run must not exceed 0.03  $\mu$ F (typically 1000 ft).

**CAUTION:** Conduit seals are highly recommended to prevent the entry of moisture into the switch. Moisture will damage the switch and void the warranty. Internal and external protective earth connections must be connected to the installation protective earth circuits.

### Power Wiring

It is highly recommended that all power and triac/FET wiring be routed separately from the external sensor, the dynamic signal and 4-20mA wiring in order to reduce AC/transient noise pickup. The power required is indicated on the nameplate. The voltage supply must be within the following limits:

**24 VDC:** 20 VDC to 28 VDC  
**115 VAC:** 95 VDC to 125 VAC, 50/60 Hz  
**230VAC:** 190 VDC to 250 VAC, 50/60 Hz

Polarity does not need to be observed when wiring for DC power. The preferred method of operation is to continuously apply power to the SW6000. If power is to be applied as a part of the machine startup sequence it is advisable to apply power to the SW6000 30 seconds prior to starting the machine in order to allow the electronics circuits to stabilize. This is particularly important if the adjustable startup delay option is utilized and the delay is set to less than 20 seconds.

### Alarm Limit Triac Output Wiring

The triac output(s) are electro-optically isolated from each other, power, and the internal circuit. These are medium-power devices with high immunity to electrical transients. If desired, each triac can be supplied from an AC voltage source different from the main supply. The triacs can be connected in series with the triacs of other units. See Figure 4. Parallel connection of two switches doubles the triac holding (minimum load) current requirements. The maximum triac supply voltage is 250 VAC. The worst case triac leakage (off) current is 2 mA. The maximum triac holding current is 35 mA at 25°C (60mA at -40°C) which requires that the relay pull-in current have a greater value. Do not use a DC supply. The triacs can be set for N.C. or N.O. operation by positioning the Limit 1 / Limit 2 switches accordingly.

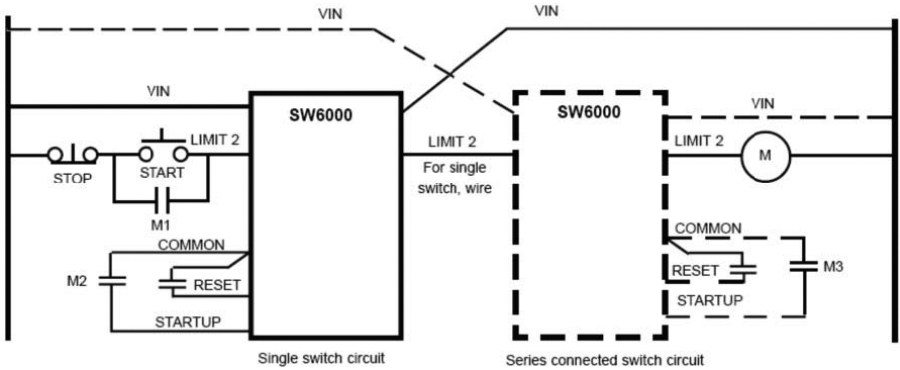

**Figure 4: Parallel connection of two SW6000**

- Set each SW6000 for N.C. (normally closed) operation. (See Figure 2)
- M2, M3 and remote reset contacts must each be isolated.

### Alarm Limit FET Output Wiring (optional)

The optional FET limit output(s) provide a low leakage switch for DC inputs to PLC's or other devices. Do not use on an AC supply. Observe proper polarity when wiring the FET(s) (See figure 2). Damage to the FET(s) will result from improper wiring. As with the triacs, the FET(s) can be set for N.C. or N.O. operation by positioning the Limit 1/Limit 2 switches accordingly.

### Limit Trip Delay

The base unit has an adjustable (1-15 sec.) limit trip delay. The vibration level must be continuously above the limit setting for the duration of the time delay before the output devices switch. The 4-20 mA output is not affected by this time delay. To reset the limit output devices, the internal reset push-button or the optional external reset push-button must be pressed. Remote reset by a N.O. push-button or momentary contacts may be made by wiring to the remote reset terminals. Note that the vibration level must be below the trip level for the reset to function.

### Startup Trip Delay

Some machines generate vibration levels during startup which are higher than normal running levels. These high vibration levels can exceed the Alarm Trip Limits which are set above the normal running vibration level. The standard SW6000 has a fixed time delay which inhibits alarm trips for 30 seconds from the closing of the startup contacts.

An optional adjustable startup trip delay (1-30 sec.) permits the Alarm Trip Limits to become operative in less than 30 seconds. Protection of machines with short startup times can be improved by utilizing the adjustable Startup Trip delay.

The Startup Trip Delay is triggered by closing a set of contacts (momentary or continuous) connected to the startup terminals. The contacts must be opened before the internal startup delay timer can be initiated again. Connecting these terminals

to a set of isolated auxiliary N.O. contacts in a motor starter is a method commonly used to initiate the startup trip delay. The 4-20 mA current output is inhibited (set to 4.0 mA) during the startup trip delay.

**Remote Reset Wiring (optional)**

If remote reset capability is desired, connect Reset terminals (see Figure 2) to a remotely located, momentary N.O. pushbutton switch. Observe hazardous area requirements if applicable.

**4-20 mA Current Source Output (optional)**

If the optional 4-20 mA output is installed, it may be connected to a remote receiver, as shown on the wiring diagram (see Figure 2). This output is a current source (at 15VDC) and requires no external loop power supply. Full scale current (20 mA) corresponds to the full scale vibration response marked on the face plate. A current of 4.0 mA represents a zero vibration condition. The maximum load resistance is 600 ohms. In high electrical noise locations a shielded, twisted pair cable is recommended.

**FORMULA:** 
$$\frac{\text{Measured mA} - 4\text{mA}}{20\text{mA} - 4\text{mA}} \times \text{Full scale vibration} = \text{Actual vibration}$$

**EXAMPLE:**







Measured mA	Full Scale Vibration	Actual Vibration
4.0	1.0 ips, peak	0.0 ips, peak
12.0	1.0 ips, peak	0.5 ips, peak
20.0	1.0 ips, peak	1.0 ips, peak

**Dynamic Outputs**

The sensor (acceleration) signal is available at the terminal block and is capable of driving a cable with a capacitance of up to 0.03 μF (typically 300m/1000 feet). Longer runs with greater than 0.03 μF of capacitance can be used without the buffer becoming unstable. However, the frequency response will be reduced due to the increased capacitance.

# HAZARDOUS AREA APPROVALS

**Warning - Cable temperatures may exceed 120°C, the user shall select cables, conductors or entry devices suitable for this temperature.**

<p>IECEx Approval (World)</p> 	<p>IEC Markings:</p> <p>Ex db IIB + H2 T5 Gb  Ta -20°C to +85°C  (no display)  Ta -10°C to +70°C (display)  IECEx CML 24.0162X</p>	<p>IEC Standards:</p> <p>IEC60079-0:2017 Ed.7  IEC60079-1:2014 Ed.7</p>	<p>WARNING-AFTER  DE-ENERGISING,  DELAY 19 MIN-  UTES BEFORE  OPENING</p> <p>AVERTISSEMENT-  APRÈS LA MISE  HORS TENSION,  ATTENDEZ 19  MINUTES AVANT  L'OUVERTURE</p>
<p>ATEX Approval (Europe)</p> 	<p>ATEX Markings:</p> <p> II 2G Ex db IIB + H2 T5 Gb  Ta -20°C to +85°C  (no display)  Ta -10°C to +70°C (display)</p> <p> CML 24ATEX1294X</p>	<p>EN Standards:</p> <p>EN IEC 60079-0:2018  EN IEC 60079-1:2014</p>	
<p>UL Approval (North  America)</p> 	<p>CSA Markings:</p> <p>  Class I, Div 1, Groups B,C,D,  T4A, TYPE 4/4X  Class I, Div 2, Groups B,C,D,  T4A, TYPE 4/4X</p>	<p>UL/CSA Standards:</p> <p>UL 50  UL 508  UL 1203  UL 61010  CSA C22.2 No.25  CSA C22.2 No. 30  CSA C22.2 No. 94  CSA C22.2 No. 142  CSA C22.2 No. 213  CSA C22.2 No. 61010  ANSI/ISA 12.12.01-  2007</p>	

info@metrixvibration.com

www.metrixvibration.com

8824 Fallbrook Dr. Houston, TX 77064, USA

Tel: 1.281.940.1802 • Fax: 1.713.559.9421

After Hours (CST) Technical Assistance: 1.713.452.9703