

162 VTS SLIM VIBRATION TRANSMITTER

Datasheet

OVERVIEW

The 162VTS is the ideal solution for sensing vibration on most plant equipment. It generates a two-wire loop signal proportional to velocity for transfer to a programmable logic controller (PLC), distributed control system (DCS) or other 4-20 mA input devices. Simply mount the transmitter on the machine case, connect the 2-wire loop and read and/or record the vibration.

FEATURES

- Loop terminals w/Independent Polarity (IPT®)
- Interfaces with PLC, DCS, 4-20 mA monitors, etc.
- Different mounting studs available
- Flying leads or terminal block connector
- Most stable detection circuit available
- “Ski slope” problem protected
- Built-in base & housing strain protection
- Improved shielding and stability

APPLICATIONS

- Blowers
- Centrifuges
- Compressors
- Engines
- Fans
- Generators
- Motors
- Pumps
- Steam Turbines
- Turbochargers



NON-HAZARDOUS AREA
VERSION (D=5)



HAZARDOUS AREA
VERSION (D=6)



Internal View - 2 pin
Terminal Block with 1/2" NPT
Threads Removed (D=6)

SPECIFICATIONS

Vibration Range	4 to 20 mA output proportional to velocity. Refer to “Ordering Option A” for ranges. Nonstandard ranges available.
Frequency Response	Standard: 2 - 1500 Hz
Axis Orientation	Any
Supply Voltage (Vs)	11-30 VDC, Non-polarity sensitive, IPT®
Isolation	500Vrms, circuit to case
Electrical Connection	2 pin terminal block (accepts up to 16 AWG wire). A cable gland is also available.
Maximum Load Resistance (R_L)	R _L = 50 x (V _{supply} - 11) ohms
Service Temp. Rating	-40°C to 100°C (T4A) (-40°C to 212°F)
Enclosure Materials	303 SS
Enclosure Environmental Rating	NEMA 4X, IP 65, IP 67 for 2 pin terminal block or flying lead option available
Agency Approvals	Refer to “Ordering Option C”

WEIGHTS AND DIMENSIONS

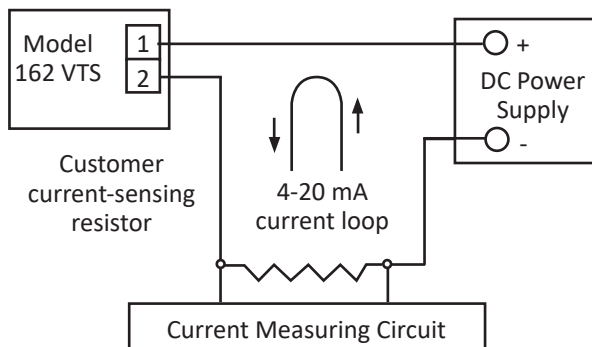
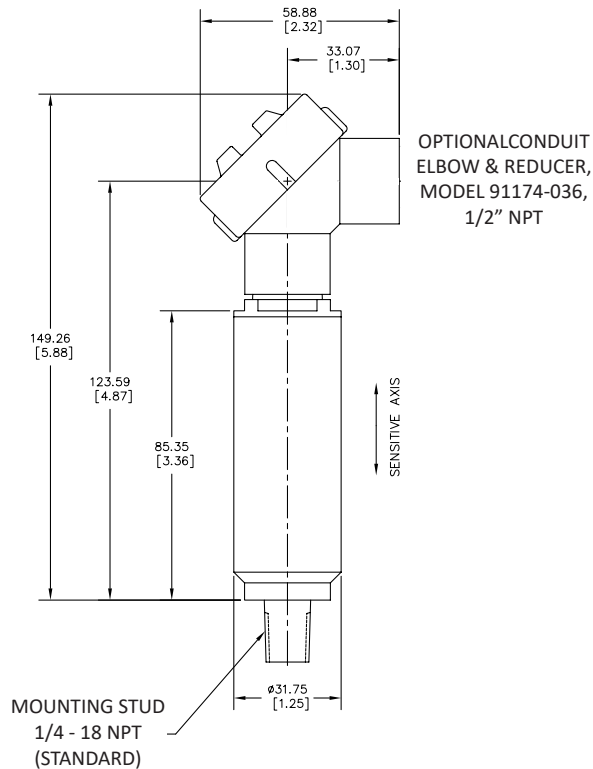
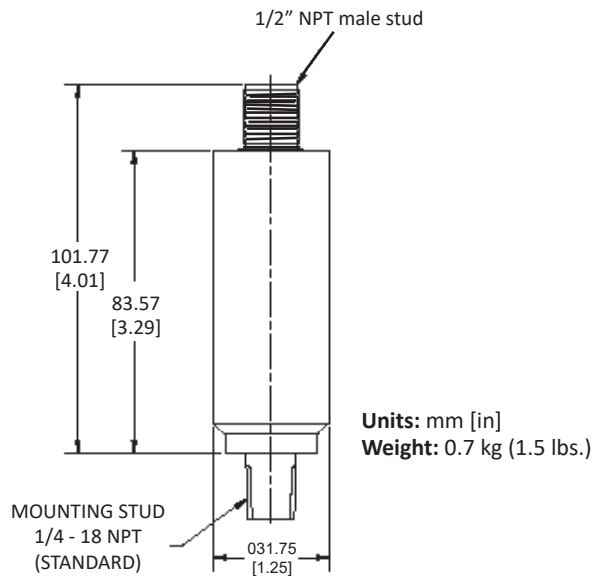

ORDERING INFORMATION

162 VTS SLIM VIBRATION TRANSMITTER			
A A A - B C D - E F			
□□□ - □□□ - □□□			
A			Full Scale
1	2	1	1.0 in/s (25.4 mm/s) peak
1	2	3	2.0 in/s (50.8 mm/s) peak
1	2	6	0.8 in/s (20.3 mm/s) peak
2	0	0	1.60 in/s (40.6 mm/s) peak
1	5	1	1.0 in/sec (25.4 mm/s) true RMS
1	5	3	2.0 in/sec (50.8 mm/s) true RMS
1	5	6	0.8 in/sec (20.3 mm/s) true RMS
2	3	0	1.60 in/sec (40.6 mm/s) true RMS
B	Mounting		
0	Integral 1/4" NPT		
2	3/8 - 24 UNF X 3/8"		
4	M8X 1 - 10		
C	Hazardous Area Certification		
3	CSA US/C Class 1, (A, B, C & D), Div 2 (non-incendive)		
4	CSA US/C Class 1, Div 1, Grps B-D (explosion-proof) and Class 2, Div 1, Grps E, F, G (dust-ignition proof). Available on the 1/2" NPT Top only (D = 5)		
5	Non-Hazardous Area Certification		
D	Connection		
5	4-20 mA; 1/2" NPT top, 24" leads		
6	4-20 mA; 2 pin terminal block (C = 3)		

Example: 162-126-455-00= 0.8 in/s (20.3 mm/s) peak scale, with M8X 1-10 mounting, non-hazardous area cert and 4-20 mA; 1/2" NPT top, 24" leads

ACCESSORIES

Product	Part Number
Conduit Elbow and Reducer	91174-036
Conduit Elbow, Reducer, 3-position terminal block (Certification Pending)	8200-004
Stainless Steel Flange Mount Adaptor	7084-002 7084-005
Two-Wire Cable Assembly	8169-75-002-XXX
Cable Gland	93818-015
Ferrite Kit	100458

Note: Metrix is continuously improving our products. Please refer to our website to download the latest version of this document. All trademarks used in this document belong to Metrix.

© 2025, Metrix Instrument Company, L.P. All rights reserved.