

5498JB Conduit Body (Junction Box)

Datasheet

OVERVIEW

5498JB Conduit Body provides a convenient junction box for internally mounted proximity probe connections. The four 3/4" NPT conduit penetrations make fitting up conduit easy. Three screw in plugs are provided to prevent intrusion through a penetration without conduit.

The integrated Low Pressure Feed Through helps prevent oil wicking with proximity probe sensors mounted in rotating or reciprocating equipment. The seal includes a split grommet that fits over the cable where access to the cable ends isn't practical. The grommet allows adjustment of the cable position. The probe cable can be connected to the extension cable within the conduit body.

Note:

- Plugs are provided for three (3) of the four conduit penetrations
- Plugs are provided to fill unused holes in split grommets (4)
- Insulated leadwires must be used; do not use bare stranded wires
- Wires must be oil sealed on sensor end

5498JB CONDUIT BODY SPECIFICATIONS

Fitting Material: Aluminum

Temperature Range: -40° to 90°C (-40° to 194°F) limited by Low Pressure Feed Through

Pressure: Atmospheric

Ingress Protection Rating: IP66 with water tight conduit connections

Connection Thread: 3/4" NPT (4)

Feed Through Thread: 3/4" NPT

Overall Length (includes Feed Through): 6.25" (180mm)

LOW PRESSURE FEED THROUGH SPECIFICATIONS

Fitting Material: 316 Stainless steel

Grommet Material: Fluoroelastomer

Temperature Range (Grommet): Fluoroelastomer: -40° to 90°C (-40° to 194°F)

Pressure: 50 psi (3.4 bar) at 20°C

Ingress Protection Rating: IP66

Connection Thread: 3/4" NPT

Process Thread: 3/4" NPT

Overall Length: 3.25" (82mm)

HAZARDOUS AREA RATINGS

Class I Div I or Class I Div II

Ex II 1G Ex ia IIC T4 Ga or Ex II 3G Ex nA IIC T4 Gc

When Used With MX8030/MX2030, MX8031/MX2031 Per Drawing #1086567 or other appropriately approved product.

* 5495 Forward Mount Probe does not have Hazardous Approvals Ratings.

"Warning" keep cover tight to prevent ignition of hazardous atmosphere, disconnect circuits before removing cover, seals are required within 6" (152mm) of enclosure on all conduits if used in a hazardous area.

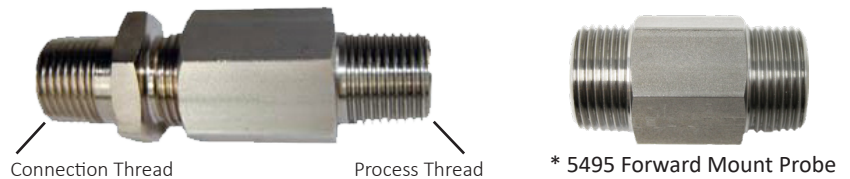
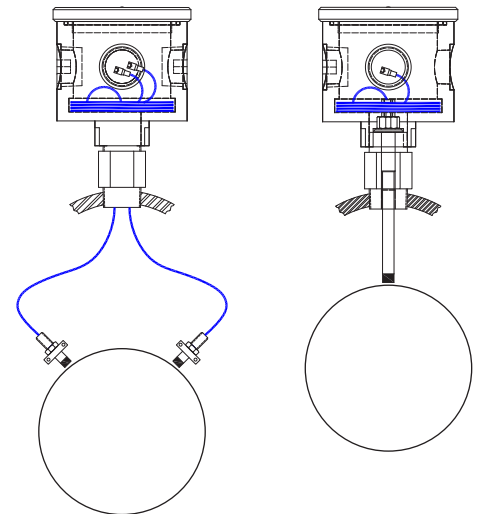

5498JB Conduit Body (Junction Box)

Datasheet

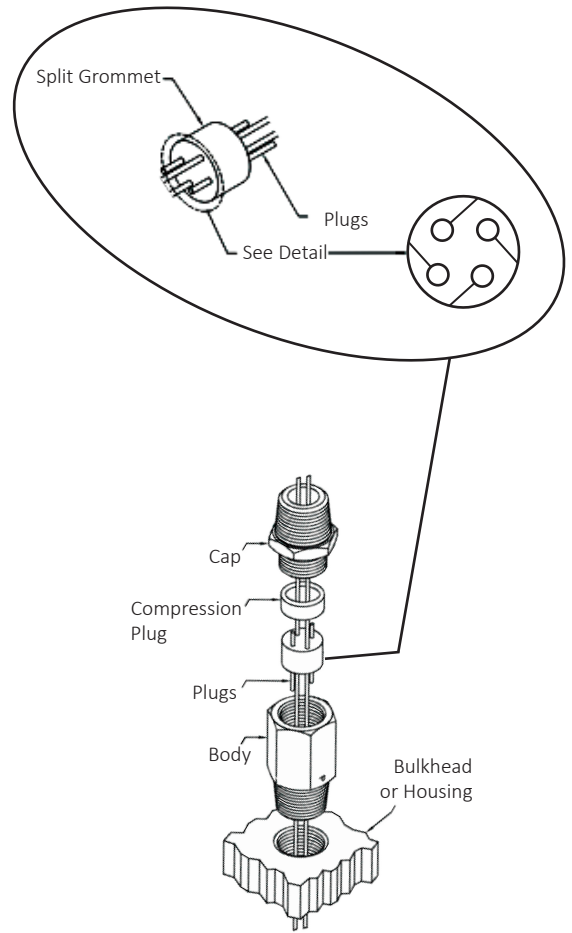
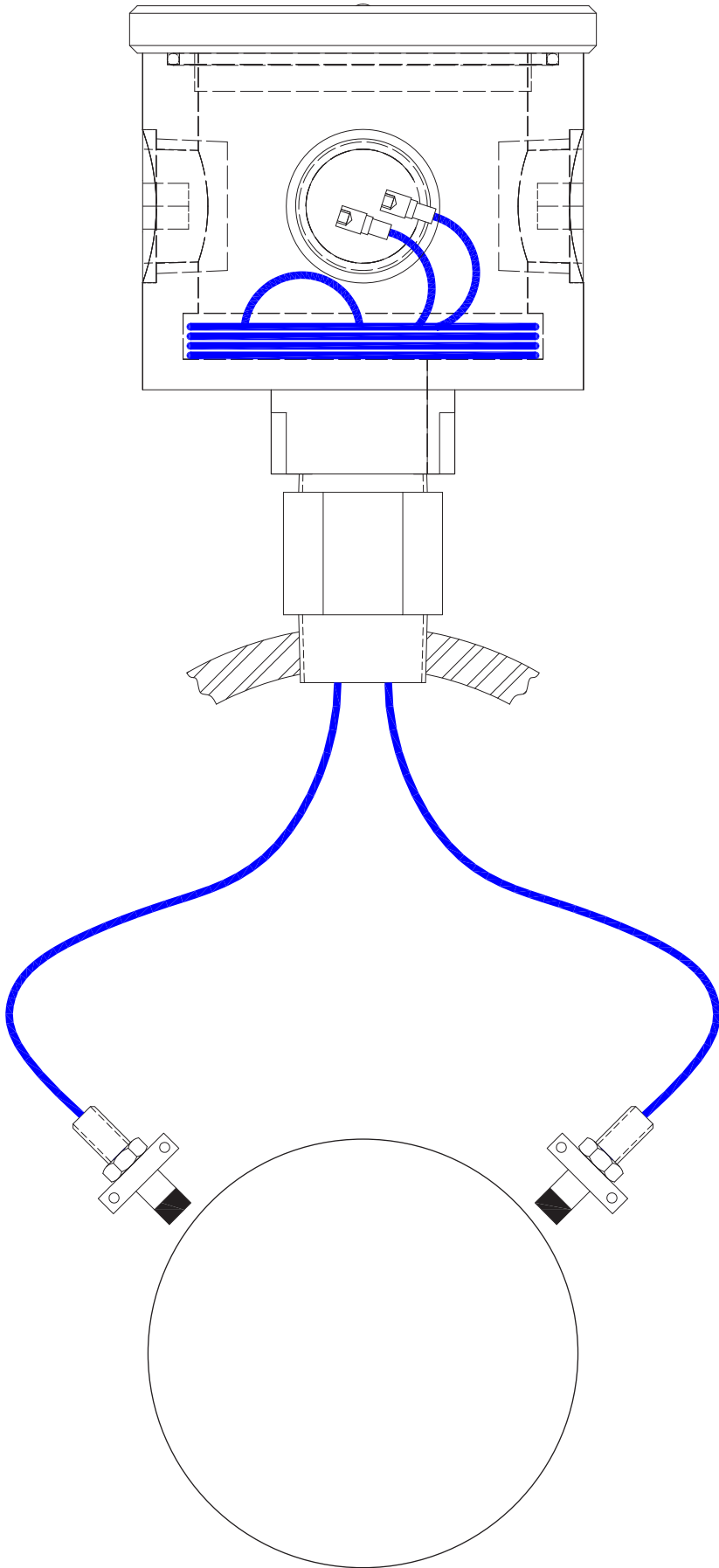

DIMENSIONS

TOP

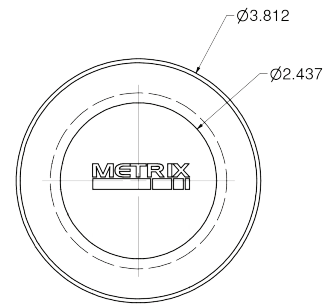
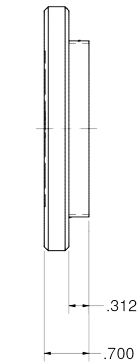
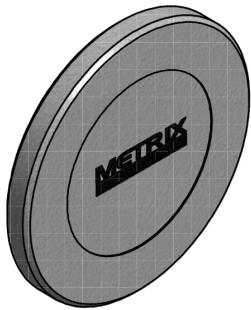

BODY

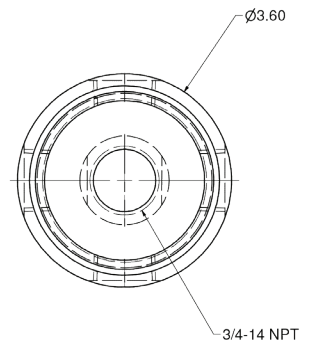
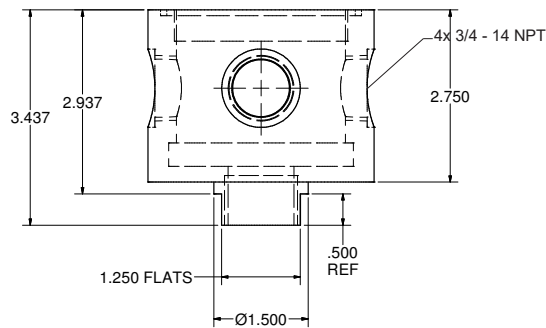
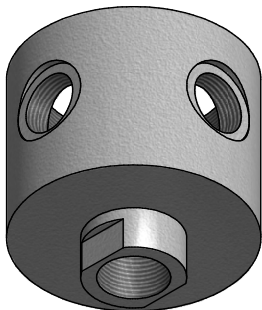

FEED THROUGH

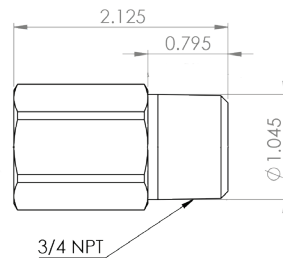
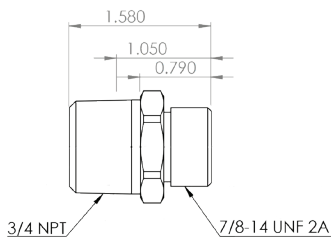

BUSHING

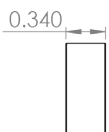

GROMMET

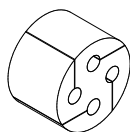

PLUGS (4)



5498JB CONDUIT BODY (JUNCTION BOX) WITH FORWARD MOUNT PROBE HOLDER

The 5498JB can be used with 5495 Forward Mount Probe Holder to provide a convenient way of directly mounting forward mount proximity probes on a machine case.

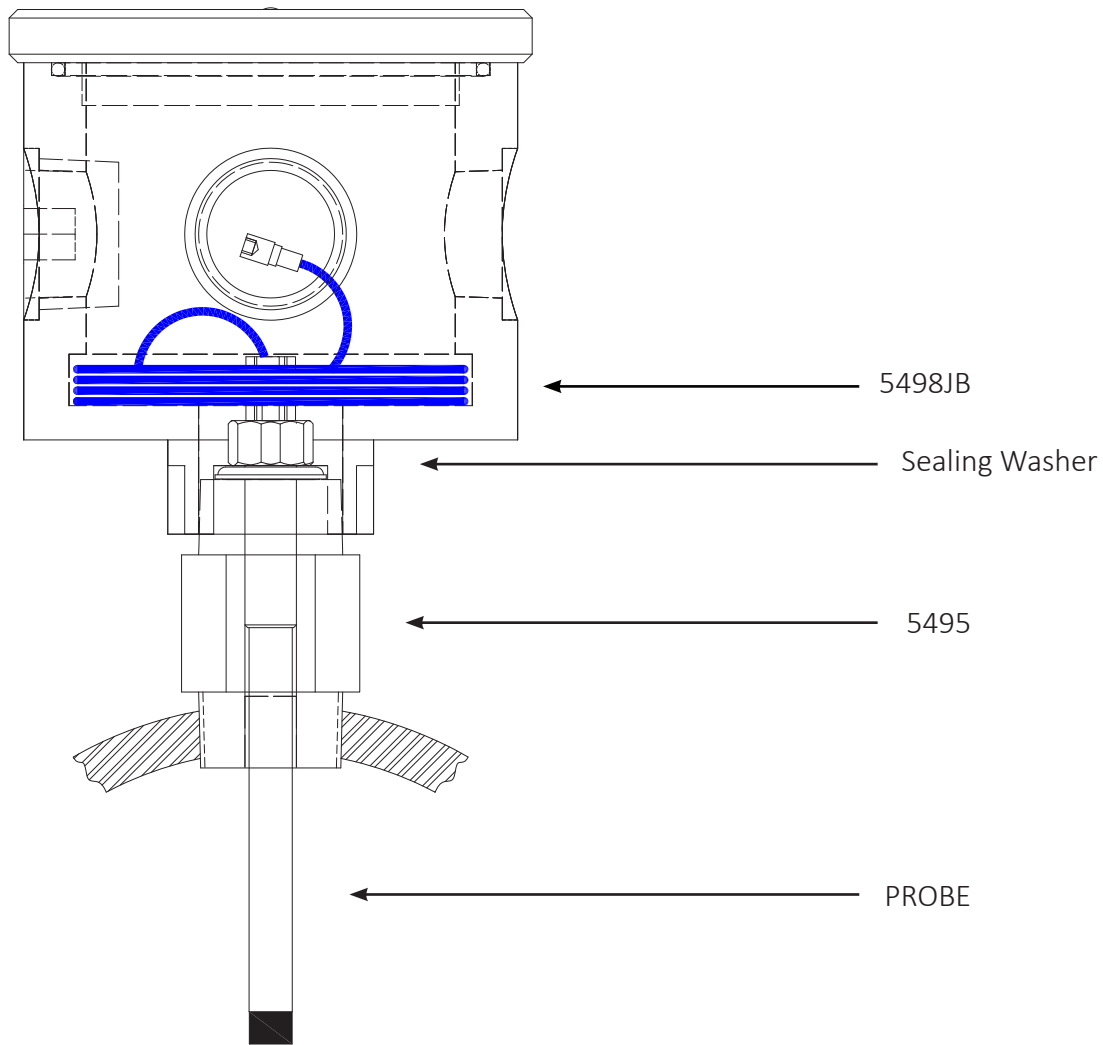

The $\frac{3}{4}$ " NPT thread on one side of 5495 Forward Mount Probe Holder is used to connect 5498JB, and the other side with either $\frac{3}{4}$ " or $\frac{1}{2}$ " NPT thread is used to mount on machine case.

$\frac{3}{4}$ - 14 NPT

To 5498JB

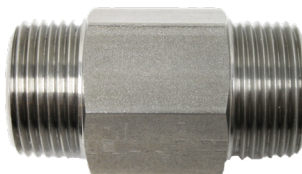

$\frac{3}{4}$ - 14 NPT
OR
 $\frac{1}{2}$ - 14 NPT

To Machine Case

DIMENSIONS

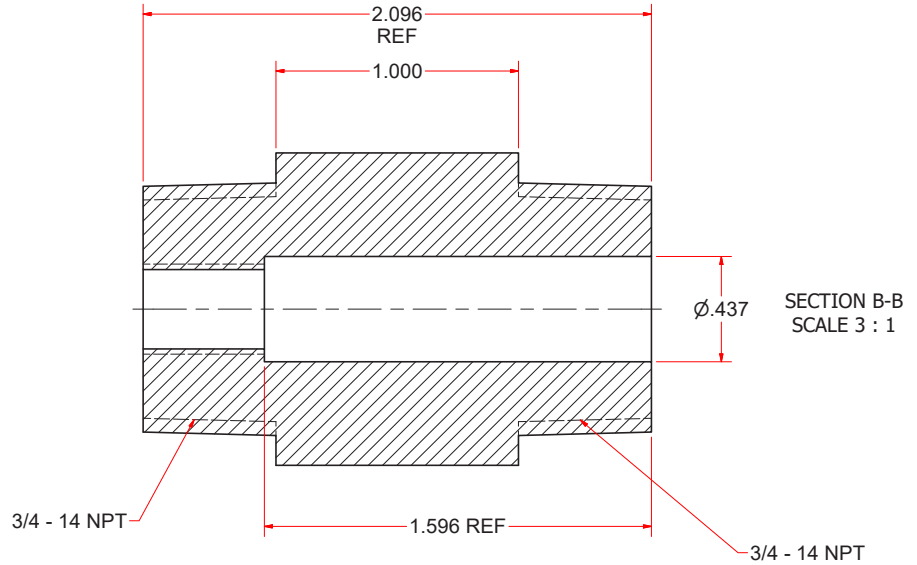
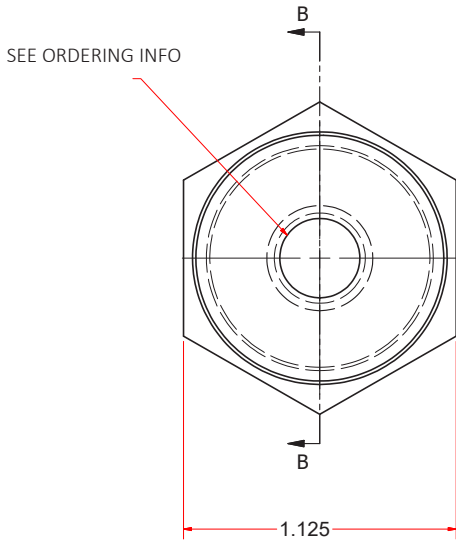

5495-001 and 5495-002

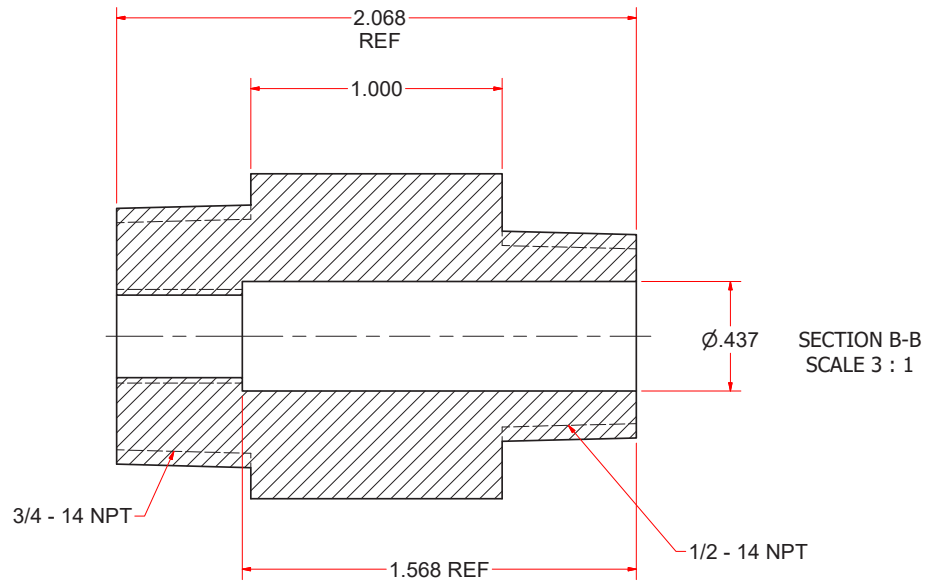
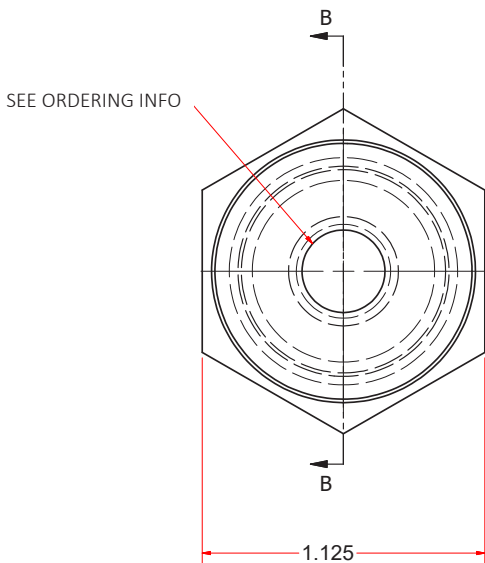

5495-005 and 5495-006



SEALING WASHER

	PART NUMBER	FOR SCREW SIZE	ID	OD	Thickness
	91201-012	3/8" or M10	0.385"	13.7mm	0.077"-0.087"
	91201-013	1/2"	0.510"	13.7mm	0.085"-0.095"
	91201-007	M14	13.7mm	22.4mm	1.1mm-1.4mm

HOW TO ORDER

PART NUMBER	DESCRIPTION
5498JB-001	Conduit Body (Junction Box) with Low Pressure Feed Through, 3/4" NPT Process Thread
5498JB-002	Conduit Body (Junction Box) without Low Pressure Feed Through
5498JB-003	Conduit Body (Junction Box) with Forward Mount Probe Holder 5495-001, 3/4" NPT Process Thread, 3/8"-24 UNF Probe Thread, sealing washer 91201-012
5498JB-004	Conduit Body (Junction Box) with Forward Mount Probe Holder 5495-002, 3/4" NPT Process Thread, M10x1 Probe Thread, sealing washer 91201-012
5498JB-005	Conduit Body (Junction Box) with Forward Mount Probe Holder 5495-005, 1/2" NPT Process Thread, 3/8"-24 UNF Probe Thread, sealing washer 91201-012
5498JB-006	Conduit Body (Junction Box) with Forward Mount Probe Holder 5495-006, 1/2" NPT Process Thread, M10x1 Probe Thread, sealing washer 91201-012
5498JB-007	Conduit Body (Junction Box) with Forward Mount Probe Holder 5495-007, 3/4" NPT Process Thread, 1/2"-20 UNF Probe Thread, sealing washer 91201-013
5498JB-008	Conduit Body (Junction Box) with Forward Mount Probe Holder 5495-008, 3/4" NPT Process Thread, M14x1.5 Probe Thread, sealing washer 91201-007

Note: Metrix is continuously improving our products. Please refer to our website to download the latest version of this document.

All trademarks used in this document belong to Metrix.

© 2024, Metrix Instrument Company, L.P. All rights reserved.